



OWNERS MANUAL & INSTRUCTIONS

by
Bruce Lambert & Ralph Resnik

July 2005

Version2

© 2005 Bruce Lambert & Ralph Resnik. All rights reserved.

The FUSION FIGHTER

A NORTH AMERICAN STYLE FIGHTER KITE

THANK YOU FOR PURCHASING A FUSION FIGHTER KITE!

This manual is filled with information to add to your enjoyment of your FUSION FIGHTER kite!

It includes:

- Details about attaching the bridle.
- Details about how to tune your kite.
- Information about how to enhance the kite's durability.
- Information about how to modify the kite if you want to experiment.
- It also includes some fighter kite flying instructions if you've never flown a fighter kite before.

There are three questions about the FUSION FIGHTER kite that are often asked:

'Where did the name come from?'

'Why isn't the bridle already attached to the kite?'

'How much wind do you need to fly a FUSION FIGHTER kite?'

THE NAME

The name FUSION FIGHTER comes from the fact that this kite is a fusion of Indian and North American fighter kite design together with Indian fighter kite building know how. Kirti Shah thought of the name, which I thought was a perfect name for this kite.

THE BRIDLE

In India, where these kites are handmade, no NEW kite is made with a bridle attached because in India if a kite has a bridle it indicates the kite is used. And that's why the FUSION FIGHTER kite does not come with the bridle installed; the bridle needs to be installed by the buyer.

THE WIND RANGE

The FUSION FIGHTER kite is designed to fly well in winds ranging from about 4mph to about 11mph which includes most wind conditions. Skilled fighter kite flyers will have the most success flying the FUSION FIGHTER in winds lighter than 4mph, but it will take some 'work'.

Installing a 3-point bridle on the FUSION FIGHTER kite

A 3-point bridle arrangement is recommended because it provides 2 adjustment points for tuning your kite. It's an easy and quick bridle to make; however, it takes a few paragraphs and diagrams to clearly describe how to do it.

1) Cut or tear out the 'Upper Bridle Template' located at the end of this information. Lay the kite with its backside facing up. Lift the bow of the kite and slide the template under the bow so the template's 'spine line' is aligned with the kite's spine and the 'nose arrow' on the template pointing toward the kite's nose. With a pen, pencil or marker, make two marks on the bamboo bow, directly above the template 'upper bridle marks', these will be 1.5" or 4 cm from the spine on the right and left sides of the bow.

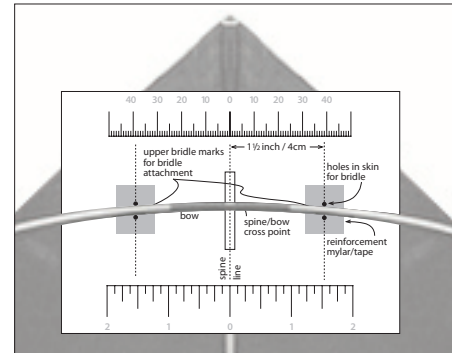

2) Remove the template. Make a mark on the Mylar directly under the 'upper bridle marks' you made on the bow, do the same on both sides of the kite.

3) There are 3 parts to the bridle. The upper bridle yoke, the lower bridle line and the tow connection loop.

4) Using a sharp round toothpick, puncture the kite skin at the marks you just made. Make 2 holes at each mark, one on each side of the bow. You'll make a total of 4 holes with the toothpick.

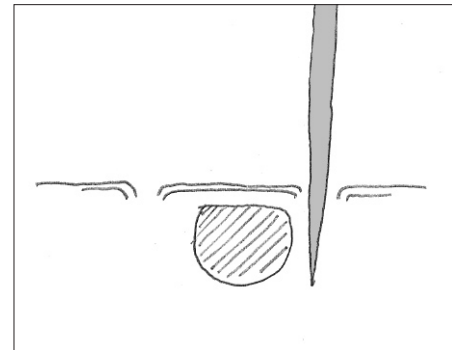
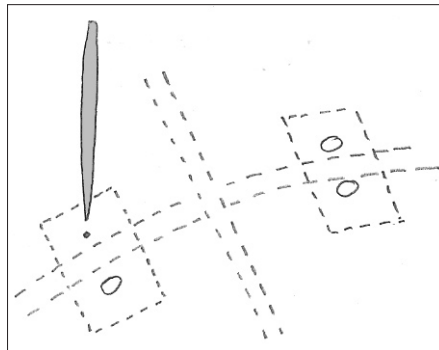

5) Work from the front side of the kite to make the upper bridle yoke. Cut a piece of bridle line about 14" long. Poke one end through one of the holes you just made with the toothpick. Poke it from the front of the kite. Bring the bridle line around the back of the bow and make one complete wrap around the bow with the line and then out to the front of the kite through the other hole you made at that upper bridle mark and tie it with any knot that will hold securely.

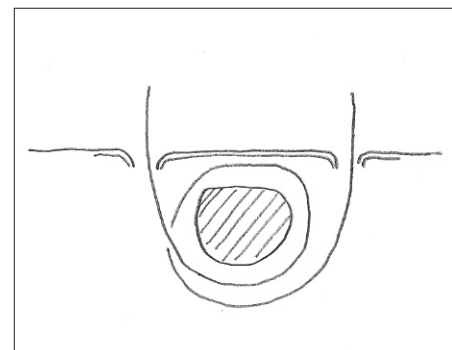

6) Now poke the other end of the upper bridle yoke through one of the holes you made at the upper bridle mark on other side of the kite and do the same with it as you did with the first end. You'll have created a loop or yoke that is on the front of the kite each end tied to the bow. The actual length of the finished loop is not critical.

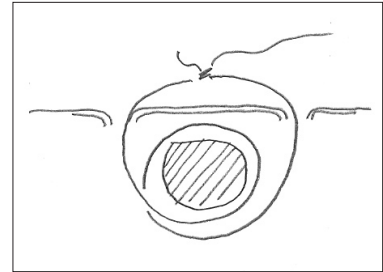

7) Instead of using a toothpick, you could use a large-eyed needle. Thread the bridle line through the eye and follow the above directions for wrapping and tying the upper bridle line.

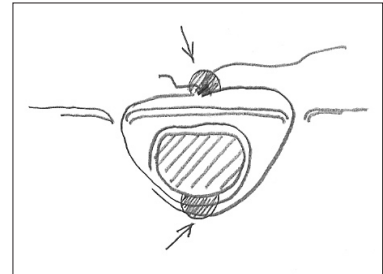

8) Turn the kite over so the backside is facing up. Slide the bridle lines so they align with the marks you made on the bow and apply a drop of nail polish to the bow and bridle line. If you are uncertain about the security of the holding power of the knot you tied, put a drop of nail polish on the knots also.

9) Cut a second piece of bridle line about 30" long. This is called the lower bridle line. Fold over about 4" on one end and tie an overhand knot creating a loop about 2.5"-3" long.

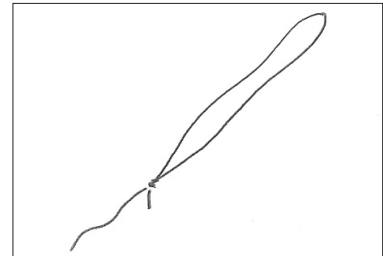

10) Using the loop you just made on the lower bridle line, attach the lower bridle line to the center of the upper bridle yoke using a larkshead knot.

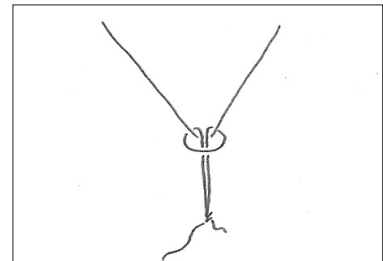

11) Using the toothpick puncture two holes, one on either side of the spine in the area of the Mylar reinforcement patch on the lower portion of the spine. The exact location is not critical as long as you make the holes in the area of the reinforcing.

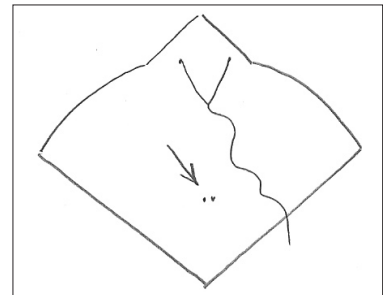

12) Poke the end of the lower bridle line through one of the holes you just made, wrap the line around the spine and out to the front of the kite through the other hole. Tie a knot that will hold securely. If you are unsure about your knot's ability to hold, put a drop of finger nail polish on the knot and on the line on the back of the spine.

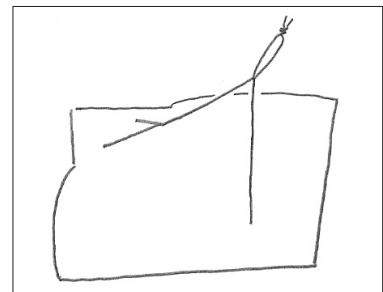

13) Cut a third piece of bridle line about 6"-7" long. Fold it in half and tie the loose ends together with an overhand knot to form a small loop about 2.5"-3" long. Attach the loop to the lower bridle line using a larkshead knot. This loop is the place you will attach your flying line to the kite. It is called the tow connection loop.

14) The last step to getting the FUSION FIGHTER ready to fly is to tie the bow and the spine together at the point where they cross. This requires applying a piece of clear tape on the kite skin at the cross point and puncturing the skin at two points, diagonally positioned so you can get a piece of line around both the spine and bow. Or you can use a large eyed needle and use it to both puncture and feed the line through the skin. On the back side of the kite, tie a knot that secures the two ends of the line.

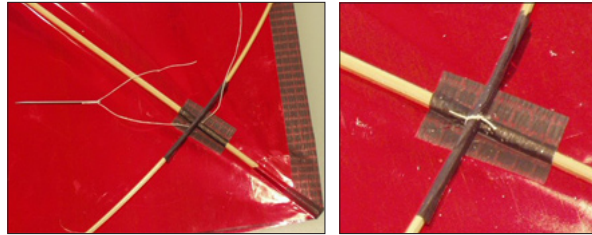

ADJUSTMENTS TO MAKE BEFORE FLYING THE KITE

1) After the bridle is completed, hold the kite by the tow connection loop. Position the loop along the lower bridle line so the tail of the kite will barely touch a table top while the nose of the kite is elevated above the table top about 1.5"-2". This pre-tunes your kite so it will fly. In most cases you'll want to further adjust the bridle to better match the flying conditions.

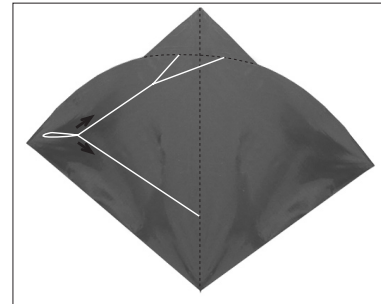

2) Next, check the shape of the spine. It should be curved outward toward the front of the kite in a gentle rocker shape. If the spine is straight or nearly straight, hold the kite with its front against your stomach. Press on the backside of the spine with your fingers about 2" below the place where the spine and bow cross. Press hard enough so you push the front side of the spine into your stomach about 1.5" and hold it there for 30 seconds or so, then move your hand down the spine about 2" closer to the tail of the kite; press and hold it for about 30 seconds. The heat from your body will set a slight bend in the spine that is needed to allow the kite to fly correctly.

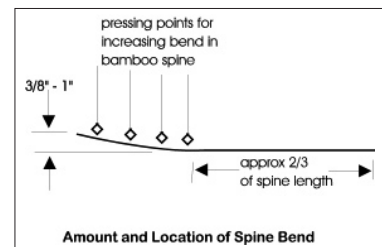

CAUTION: Bamboo can be broken if you try to bend it sharply at one spot. Gently press on various points along the back of the spine in the bend area of the spine. This will produce the modest “rocker” bend that is ideal. The tail portion of the spine starting about 2" (50mm) noseward from the lower bridle connection point on the spine to the tail of the spine should be straight.

NOTE: Bridle adjustment points are made to be adjusted. Carefully adjusting the bridle is how your kite will become a ‘perfect flyer’.

ATTACHING FLYING LINE TO YOUR KITE'S BRIDLE

On the end of your flying line fold over about 12" of line and use an overhand knot to form a loop about 10" long. Next, 2" from the end of that loop, tie another overhand knot, forming a smaller loop at the very end of the first loop. The larger loop is what you will use to make a larkshead knot around the knot of the tow connection loop on your bridle. This is how you attach your flying line to your kite bridle. The small loop will help you release the larkshead knot easily when you're finished flying by simply pulling on it while holding the tow connection loop.

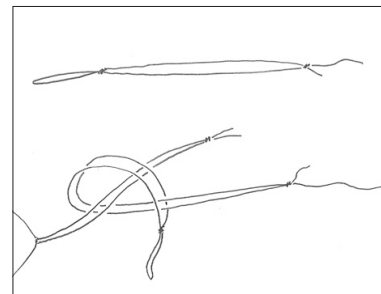

UPPER BRIDLE TEMPLATE

There are two bridle templates for your convenience

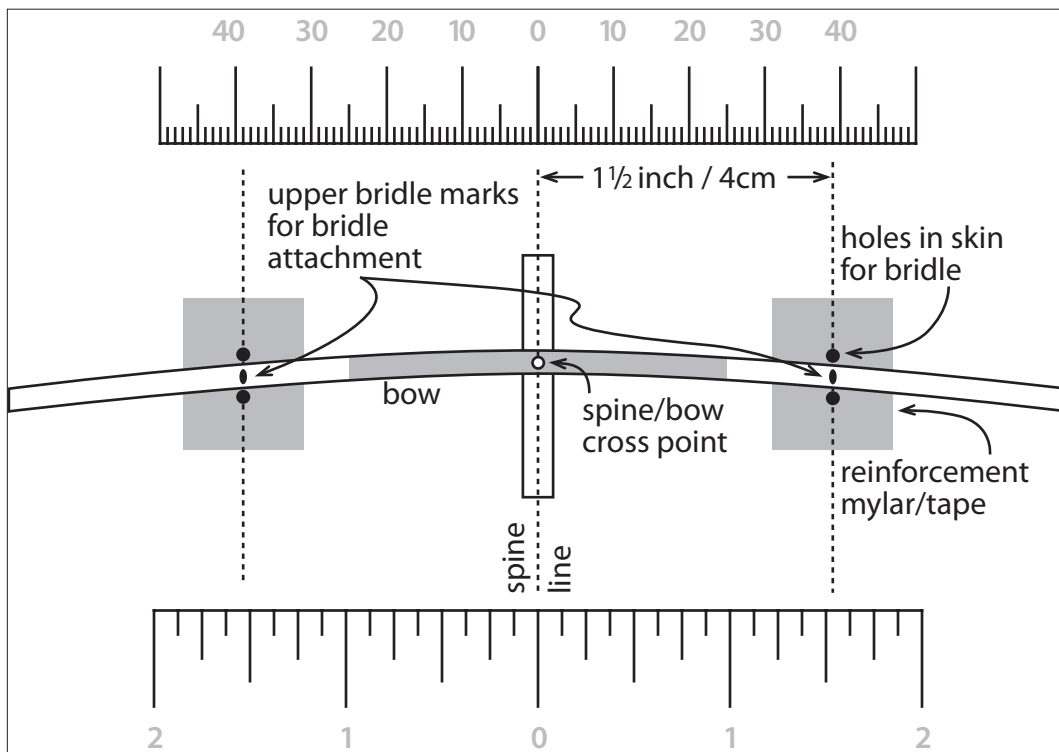
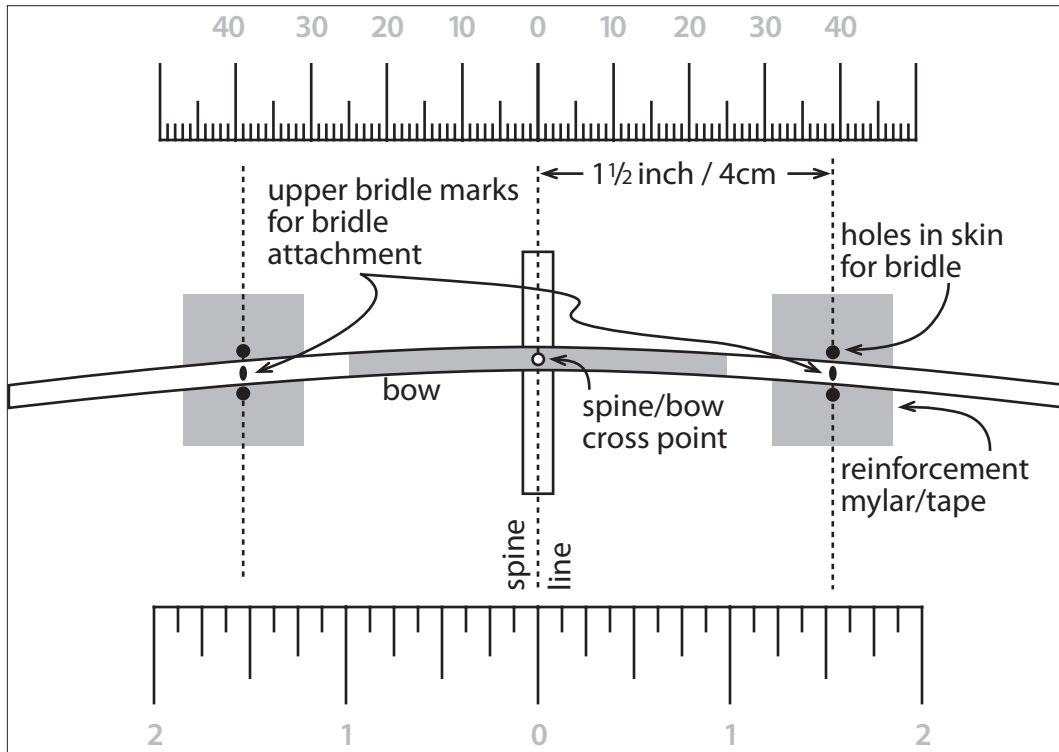

Tuning & Adjustment Tips for North American style Fighter Kites such as the FUSION FIGHTER

ADJUSTING THE TOW CONNECTION LOOP

The tow connection loop can be moved up or down along the length of the lower bridle leg to create changes in the kite's performance.

Generally, moving the tow connection loop towards the nose of the kite does three things:

- A. Reduces the amount of pull you feel on the flying line.
- B. Increases the kite's willingness to enter into a spin when the tension on the flying line is reduced.
- C. Increases the kite's forward speed.

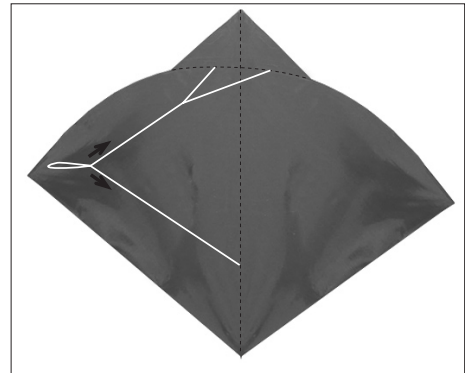

Generally, moving the tow connection loop towards the tail of the kite does three things:

- A. Increases the amount of pull you feel on the flying line.
- B. Reduces the kite's willingness to enter into a spin when the tension on the flying line is reduced.
- C. Reduces the kite's forward speed.

Move the tow connection loop along the lower bridle leg about $\frac{1}{8}$ " or less at a time. Fly the kite after moving the tow connection loop and see if the change is sufficient, if so fine, if not, continue adjusting until the kite is flying to your liking. There is no 'RIGHT' or 'WRONG' position of the tow connection loop. Experimenting is the way to learn what effect it has and how you like the various changes in the kite's performance.

IF YOUR KITE DOESN'T FLY STRAIGHT

While flying your kite with strong tension or pulling sensation in the flying line, if it consistently curves, spins or veers to one side, and won't fly straight, your kite's bridle needs a small adjustment. In this case you'd adjust the 'right-left' balance adjustment of the bridle. The 'right-left' balance adjustment is the adjustable larkshead knot on the upper bridle leg or 'yoke'.

HERE'S WHAT TO DO

If the kite is spinning or turning constantly to the right side, it is telling you the length of bridle line on the right side of the yoke is too short. So move the knot on the 'yoke' to the left, this lengthens the right side portion of the bridle yoke. If the kite is constantly turning or spinning to the left, move the knot on the 'yoke' to the right.

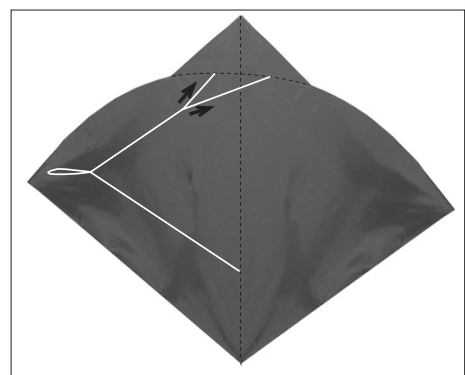

This 'right-left' adjustment is a very sensitive adjustment. Move the knot only about 1/64" (0.5mm) at a time, then fly the kite to see the results of your adjustment. Continue adjusting and flying until the kite is flying straight.

NOTE: All the references to right and left are based on positioning the front face of the kite so it is facing you, like it would be when you are flying the kite.

CONTROLLING YOUR FIGHTER KITE'S SPIN

The Tow connection loop adjustment is the bridle adjustment that affects the kite's tendency to spin. The spin rate itself is controlled more by the curve of the spine and the balance of the kite.

Moving or sliding the tow connection loop's along the lower bridle line toward the tail of the kite will reduce the kite's tendency to spin, it will slow the kite's speed and will make the kite more stable.

Moving the tow connection loop toward the nose of the kite will increase the kite's tendency to spin and slightly increase its speed.

Positioning the tow connection loop at an extreme position; whether nearer the nose end or nearer the tail of the lower bridle leg will create a bridle setting that may not allow the kite to fly.

ADJUSTING THE BAMBOO BOW

If the bridle adjustments don't provide a straight flying kite, then it may be necessary to make a slight adjustment to the bow. For example, if the kite is turning to the right consistently and adjusting the bridle does not correct it, it may mean the left side of the bow is slightly stiffer or stonger than the right side.

In the example above, to correct the constant 'right' turning of your kite, first, set the bridle knot on the upper bridle yoke to be centered above the spine; to do this unlock the larkshead knot and move the knot to the center location and relock it. Next put a pea sized piece of putty on the backside of the left wingtip. Fly the kite and if it flies straight, all is good, but if it still consistently turns one way, adjust the amount of putty until the kite flies straight.

If the kite is turning consistently to the left, you will add the putty to the backside of the right wingtip of the bow. A combination of putty on the wingtip and bridle adjustments is typically what will correct a severely turning kite. This is a rare occurrence so you probably won't need to be concerned with it.

NOTE: The type of putty that works well is the 'sticky or tacky' stuff used to hang pictures on the wall without using nails. It's inexpensive and available at any hardware store, hardware or craft departments and in craft stores.

REDUCING THE AMOUNT OF SPIN

Many flyers don't care for a fighter kite to spin too fast or too often, especially when they are learning how to fly one. The easiest and best solution for controlling this aspect of fighter kites is to add a tail to the kite. The tail can be made of almost any material and should be about 1" wide and about 6'-8' long. Use a small piece of tape to attach one end of the tail to the backside of the kite at the tail end of the spine. If you find a single tail does not control the activity of your kite enough, add a second tail. If you want the kite to become more active, cut off about $\frac{1}{3}$ to $\frac{1}{2}$ of the tail ... this will increase the spinning and activity of the kite.

INCREASING THE SPIN

If you want the kite to spin more than it does, add a pea sized piece of putty to the backside of the spine near the tail. After adding the putty, fly the kite to see if it spins to your liking, if not, add more putty until the kite spins as you want it to.

NOTE: The type of putty that works well is the 'sticky or tacky' stuff used to hang pictures on the wall without using nails. It's inexpensive and available at any hardware store, hardware or craft departments and in craft stores.

TIPS

for Enhancing Durability & Performance of Your FUSION FIGHTER Kite

With most fighter kites, there are simple small changes that a flyer can make to the kite that add to its durability and performance; here are some of those changes. For the FUSION FIGHTER kite the changes are minor and easy to do. However, the FUSION FIGHTER needs none of these to fly well, but some of us are curious and enjoy 'tweaking' our kites; I suppose it's the 'inventor' in all of us.

DURABILITY ENHANCEMENTS

Adding a small amount of 'Scotch' type clear tape to the locations mentioned below will add to the durability of your kite and it takes very little time. NOTE: I used black tape so it would show in the photos. The photos show only one side of the kite with tape, both sides must have tape applied.

A. Apply $\frac{1}{2}$ " to $\frac{3}{4}$ " wide clear tape to the nose leading edge on the back side of the kite.



B. Apply a piece of clear tape about $\frac{3}{4}$ " x 1" to each of the 'corners' where the nose leading edge meets the bow. This piece of tape will wrap from the front face of the kite skin to the backside around the bow.



C. Apply a piece of clear tape about $\frac{3}{4}$ " x $\frac{1}{2}$ " to each of the wingtips. Photo above.

D. Apply a piece of tape about $\frac{1}{4}$ " wide x $1\frac{1}{2}$ " long to both the nose and tail of the spine. This piece of tape will fold over the end of the spine – about half of the tape will be on the back of the spine and the other half on the front of the kite.



PERFORMANCE CHANGES

Each of the following changes in the kite will change the performance of the kite. Not all flyers agree that these changes actually improve performance, but most do. I suggest making one change at a time and fly the kite following the change to notice the effect, and more importantly, determine if you like the new performance better or not. In the photos, the marker lines indicate the general shape of the leading edge of the nose and the trailing edge. The marker lines are only shown on one side of the kite but the changes must be done equally to both sides of the kite.

1. By removing a small amount of the nose leading edge material, you can increase the kite's speed slightly and quicken the kite's reaction to your line manipulation. Here's what to do. After applying tape to the nose leading edge, cut the edge so the final shape is a slight scallop beginning at the nose continuing in a smooth shallow curve to the point where the nose leading edge meets the bow. At the maximum scallop point the distance inward from the standard nose leading edge should not be more than about $\frac{1}{4}$ "; this is a slight curve. In the photo one side of the nose leading edge has tape, the other is without tape and marked with the general shape of the curve. However, cut the curve only after you have applied the tape.

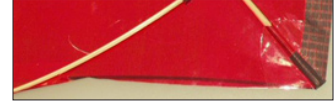

2. By removing a small amount of the trailing edge material the kite's speed may be increased slightly. Some kite makers and flyers don't think it is a benefit, and many do. Here's what to do. Cut the trailing edge so the final shape is a slight curve or scallop beginning at the wingtip continuing in a smooth shallow curve to the tail of the spine. The maximum amount of scallop should occur near the location of the batten and shouldn't be more than about $\frac{1}{2}$ " inward from the trailing edge. This will require cutting off a small portion of the battens and may require applying a small piece of clear tape to re-secure the battens to the kite skin.



When cutting the trailing edge shape, make the entire cut with one pass with your razor blade or hobby knife. If you stop and restart there is a chance you may create a nick in the skin material. The nick is a weak point and increases the chance of a tear in the skin.

REPAIRS

Repairing tears in the skin is easy to do. Simply use a piece of clear tape to secure the torn piece. If you damage a bow or spine, generally it is best to remove the damaged one and replace it with a new one.

Flying Tips For New Fighter Kite Flyers

WIND RANGE

The FUSION FIGHTER kite is designed to fly well in winds ranging from about 4mph to about 11mph which includes most wind conditions. Skilled fighter kite flyers will have the most success flying the FUSION FIGHTER in winds lighter than 4mph, but it will take some 'work'.

Flying the FUSION FIGHTER in winds stronger than 11-12mph could possibly damage the kite. The potential damage could include tears in the Mylar skin material and/or some glued points coming unglued allowing the skin to separate from parts of the bamboo frame. The glue may release because of the unusual amount of vibration of the skin that takes place when flying in such high winds.

High wind damage is not difficult to repair. If any of the skin becomes unglued from the bamboo, use a toothpick to apply contact cement to the unglued areas, let the glue dry and then press the skin and bamboo together to secure the bond and they will be as good as new. If any tears occur in the Mylar skin, use clear packing tape or Scotch type tapes to patch a tear.

CRASHES

Crashes are a fact of life in the world of flying North American style fighter kites. The most experienced flyers crash and they crash often. The difference between a crash of an experienced flyer and a beginning flyer is the intensity of the crash.....how hard it hits the ground. The beginning flyers have the most violent crashes and are more likely to damage a kite during repeated crashes. This is NORMAL. If you are a beginning fighter kite flyer expect that you will damage a kite or two and possibly destroy one during your early learning. When learning to fly fighter kites expect crashes to occur.

Thankfully Crash damage to your FUSION FIGHTER kite is easy to repair in most cases. Usually the crash damage will be in the form of a tear in the Mylar. In that case, use packing tape or Scotch type tapes to patch the tear.

If crash damage occurs to a bamboo bow or spine, it is best to replace the damaged piece of bamboo when you get home and for the moment, fly a different FUSION FIGHTER kite; a non-damaged one.

FLYING YOUR KITE

When teaching a person to fly a fighter kite, often their first question is, "how can I identify which of the 4 corners of the kite is the nose and which is the tail?" This is a natural point of confusion for new flyers, especially if the kite is a solid color, because most fighter kites appear in the sky as a 'square' or 'diamond' shape with essentially four equal looking corners.

One of the things I suggest is to put a large easy-to-see marking or decoration on the nose of the kite to make it easier to distinguish from the other "corners". Or even better is to attach a temporary tail to the tail of the kite. The tail will do 2 things; (1) it will make it easy to determine which end of the kite is the nose, (2) it will slow the kite speed providing you with more control of its flight.

A fighter kite isn't supposed to be stable staying in one spot in the sky like most single line kites. It's designed to be active and basically 'unstable' or 'erratic' when left to its own way in the sky. Sometimes they are described as having unpredictable behavior. The truth is once you understand them, they are completely controllable.

When you are new to fighter flying, slowing the kite will make it easier for you to have immediate control! The easiest method I know to do this is by adding a tail to the kite. Use a small piece of masking tape to temporarily attach a tail to the backside of the tail end of the kite's spine. The tail should be about ½-1" wide and about 4'-6' long. It can be made of paper, survey tape, several pieces of yarn or string, plastic bags cut in strips, or anything that is handy.

Once you have learned to control the fighter kite with the attached tail, you'll be ready for a livelier kite. To make it more active reduce the length of the tail by about ¼ its length. Each time you are ready for a livelier kite, shorten the tail. When you have removed the tail completely, you will have the flying skills to control the kite! Also you will have a good idea of the kite's characteristics and will not be so surprised by its actions.

BEFORE YOU BEGIN TO FLY

1. The most common flying line reel is called a 'Gator style' reel. It is popular because it allows the line to freely spool off of the reel as it is sitting on the ground at your feet and it's easy to wind the line onto when you are finished flying. When you buy flying line, it usually comes on a small diameter core of plastic or cardboard. Transfer the line from its original spool to the Gator Reel and you're ready to go!



2. After connecting the tow connection loop to the end of your flying line, place your flying reel's flat surface on the ground near your feet. With the reel in this position you are able to freely pull line off of the reel.

3. Sometimes, the wind may blow the loose line around on the ground and cause the line to get tangled and twisted. This is a normal part of fighter flying and is easy to deal with! Just break or cut the line on either side of the tangle, remove the tangle, tie a knot to reconnect the 2 ends of the line and get back to flying! Be sure to properly dispose of the tangled line. Don't leave it on the flying field where it might cause injury to children or animals!!



Photo by Sharon Musto. Used with permission.

TWO IMPORTANT TERMS

Before describing some basics about fighter kite flying, there are two terms that are important to understand.

The first is '*flying line tension*', '*pull*', '*apply tension*', '*pulling line*' or '*retrieving line*'. Each of these terms means essentially the same thing. What all of these terms are referring to is the creation of tension or a feeling of 'pull' in your flying line between you and the kite.

This can be caused or created by strong wind alone or by a combination of you retrieving flying line together with the wind strength or on very light wind days it can be caused exclusively from the action of you retrieving or pulling in flying line. When you pull in or retrieve line you drop the retrieved line, one hand full at a time, on the ground at your feet and the retrieved line accumulates on the ground around your feet.

The second term is '*releasing*'. This term refers to the easing or releasing of your grip on the flying line. As you release your grip more and more you are allowing the flying line to flow through your fingers with very slight finger pressure on the line. The kite is 'taking' the line from you because the wind is pushing the kite away from you. The accumulated line at your feet will be taken by the kite in this situation.

The flying line length is always changing. By pulling in line you shorten it and by easing or releasing the line you lengthen it.

EASIEST LAUNCH

When flying a fighter kite ALWAYS stand with your back to the wind. Then have a friend walk your kite down wind about 30' to 40'. Have the friend hold your kite above their head with the kite's nose pointing straight up. When you are ready to fly, have your friend let go of the kite the moment you begin to pull in, or retrieve your flying line. If the wind is strong enough, you won't need to pull or retrieve much flying line, the wind will do most of the work of launching your kite. If the wind is light, you will need to pull with gusto.

Hopefully at the moment of launch, the nose of the kite was still pointed straight up so the kite ascends! If not, it most likely will crash. Crashing is part of learning, even the most expert flyers crash. Just take it in stride!

ALTERNATE LAUNCH

Hold the kite in the air at arms length above your head and in front of you, kite nose pointing straight up. Then, as you keep a very slight amount of tension on the flying line, release the kite and allow the wind to take it away from you, it will be pulling line through your fingers, so be sure to hold the line very lightly with your fingers so you let the line go with the kite. Then, each time you notice the nose of the kite pointing up, pull or tug firmly on the flying line to make the kite gain some altitude, then release your grip on the flying line so the kite takes out more of the line. While the kite is moving away from you and spinning, notice when the nose of the kite is pointed upward again. At that moment, tug or pull quite hard again on the line to make the kite gain more altitude and repeat this pulling and releasing process until the kite is as far away from you and as high up as you want.

BASIC FIGHTER KITE CONTROL

A fighter kite's flight path is controlled by applying and changing the amount of tension or 'pull' you feel in the flying line. It's that simple.

When you ease or release your grip on the line, the line becomes slack or may have very little tension. In this situation the kite will normally turn, or spin. When you apply strong tension or 'pull' to the flying line, the kite will fly in a straight path; its direction will be the direction the nose of the kite was pointing the moment you applied the tension to the flying line.

FUNDAMENTAL FLYING TIPS

1. Always focus your attention on the nose of your kite. The kite nose is your indicator of the direction the kite will be traveling next!
2. The direction the nose of the kite is pointed at the time you apply tension to the flying line, by pulling on or retrieving the flying line, is the direction the kite will travel. It will continue traveling in that direction so long as you continue to apply consistent tension to the flying line. When pulling line in, or retrieving line, use a hand over hand motion and drop the retrieved line on the ground.
3. Hand over hand line retrieval works like this; jab one hand out toward your kite as fast and far as you can, grip the flying line at that point and quickly bring that hand in toward your body. At the same time as your hand holding the flying line is moving toward your body, you quickly jab the other arm and hand out as far toward your kite as it will go and grip the line at that point. At the moment the second hand grabs the flying line, you let go of your grip with the first hand, dropping the line on the ground, and immediately jab it toward the kite as far as it will go and repeat the process. This is the normal way of handling flying line when you're flying.
4. If the kite is flying in a straight path and you reduce, ease or release the tension of the flying line, the kite will most likely begin to turn, spin or change directions. Exactly what it does depends on the tuning of your kite and the degree of change in tension on the flying line at that moment. The change of tension you apply to the flying line is what causes the kite to change its direction.
5. When the kite is spinning, watch the kite's nose. When you anticipate the direction of nose is going to point up, or in the direction you want the kite to travel next, apply line tension by pulling in or retrieving the flying line and the kite will begin flying in a straight path in that direction.
6. The amount of tension you apply to the flying line and the changes in tension you give the line are the only commands you need to precisely control your fighter kite.

UNIVERSAL LAWS OF FIGHTER KITE FLYING

When the kite is in a nose dive headed for the ground, the natural tendency of a new flyer is to pull on the line in an effort to prevent an inevitable crash. However, pulling on the line at that moment will only insure a quicker more violent crash! The way to avoid a crash during the kite's nose dive toward the ground is to **RELEASE THE LINE!!!** Let the flying line become slack; let it run freely through your fingers! Doing this will eliminate 90% of nose dive crashes.

After you have released the line, and hopefully you did it in time to avoid a crash, you'll notice the kite is probably spinning or turning, plus, it's being pushed away from you by the wind, and the flying line is flowing through your fingers. Watch the kite nose carefully and when the nose of the kite is pointed upward, begin retrieving or pulling in line. Remember to pull or retrieve line ONLY when the NOSE of the kite is pointed UP, if the nose is pointed down, release the tension on the flying line and let the line be pulled through your fingers. Remember, when you apply tension to the flying line, the kite goes in the direction the nose is pointing at that moment, even if the nose is pointed toward the ground!

MORE FUN WITH FIGHTER KITE COMPETITIONS

After you have enjoyed flying your FUSION FIGHTER kite and become proficient at controlling it, you may want to engage in fun competitions with other fighter kite flyers. There are many different competitive games fighter kite flyers play.

Because the FUSION FIGHTER kites are essentially identical one to the other, it opens the door to 'One-Design' competitions, where each participant must fly the same kite as all other competitors. The primary purpose of any fighter kite competition is to have FUN! And that is especially true in a one-design competition because every participant's kite has the same opportunity to be the winner as any other participant's, what fun!

All you need to do is develop rules that you and your opponent agree on and begin the competition....it's very easy! If you want to use established North American style fighter kite games and rules, you can find the various rules on line at www.nafka.net and <http://www.aka.kite.org/>.

If you want more information about fighter kites check out www.nafka.net, the official website of the NORTH AMERICAN FIGHTER KITE ASSOCIATION. It has a ton of information, plans so you can make your own fighter kites and other resources relating to fighter kites.

I hope these ideas will add to your enjoyment of flying your FUSION FIGHTER kite!

BigGrins,
Bruce

CONTACT INFORMATION

Bruce Lambert – kitefighter@nwinfo.net

NAFKA - The North American Fighter Kite Association – <http://nafka.net/>
The main network for fighter kites worldwide!

<http://www.one-world-trading.com>
Kirti Shah, owner – Ft Worth, Texas, USA.

ACKNOWLEDGEMENTS

Ralph Resnik – design, creation and illustration – phighter@gralphica.com